

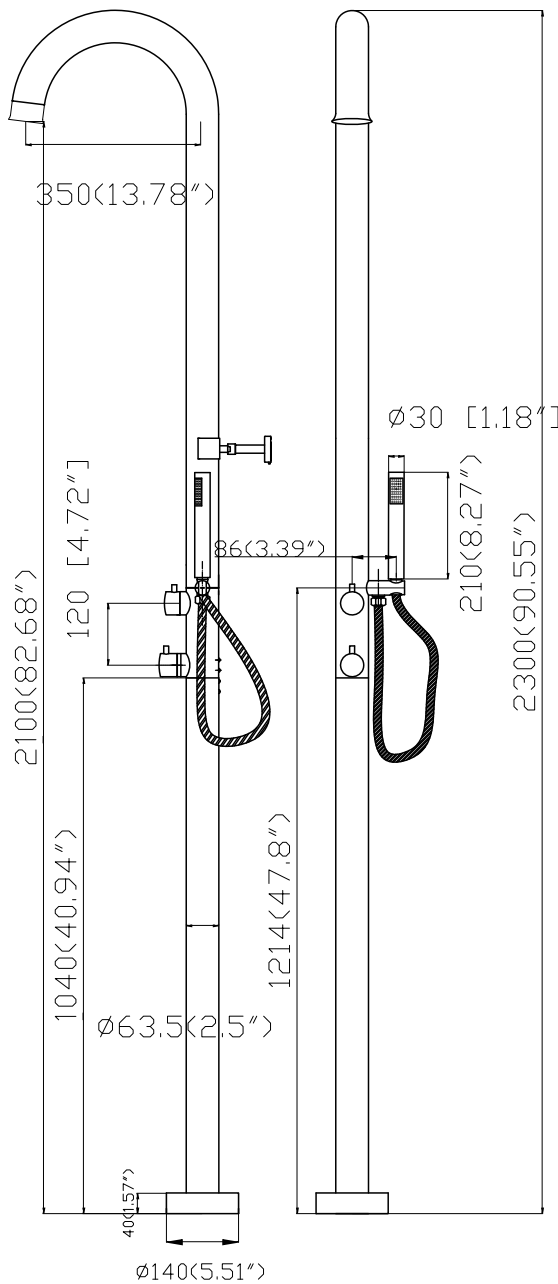

JEE-O original shower O2TH specifications

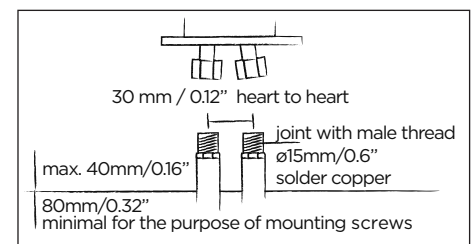

Note:
UV radiation and extreme temperature can affect the color and structure of the JEE-O original surface.



Article code: **100-6310** (brushed)
100-6311 (polished)

Material: Stainless Steel r304
Cartridge: Hain-Yo ceramic diverter mechanism
Sedal Mixing mechanism (thermostatic)

Cleaning: JEE-O protect
Connection: nylon^(out)/epdm⁽ⁱⁿ⁾ flexhose
with brass swivel

Flexhose: 150 cm length

Flow at water of 38°C / 100,4°F: 12l / 3.2 gal p/m at 3bar pressure

Dimension package: L 158 x W 18 W 54 x H 21 cm

Total weight: 13.2 kg / 29.1 lbs
Package weight: 2.0 kg / 4.4 lbs

Placing on a water-tight floor

2 year warranty

HS code: 84818011900

